

DEBIX LoRa Board

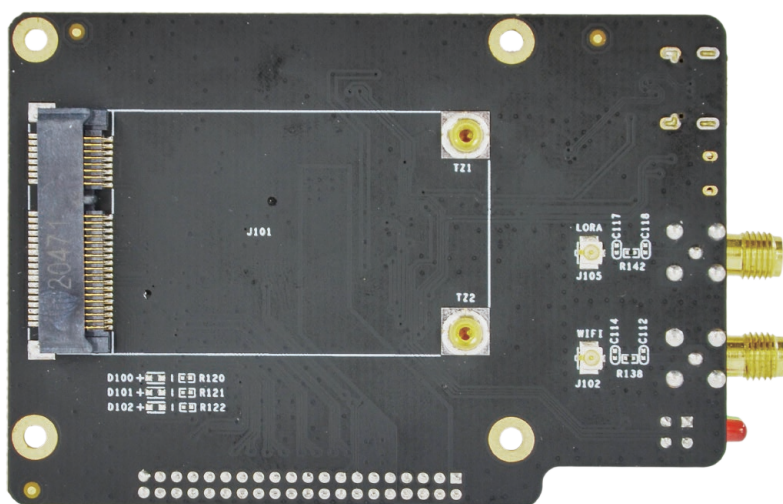

DEBIX LoRa Board

Overview:

DEBIX LoRa Board fits DEBIX Model A/B and DEBIX Infinity, and provides a Mini PCIe interface for LoRa Module. LoRa enables long-range transmissions with low power consumption. In addition to a LoRa Antenna Connector, it also has a Wifi Antenna Connector and Bluetooth Pairing Button.

Compatibility:

Compatible with DEBIX Model A, DEBIX Model B, DEBIX Infinity

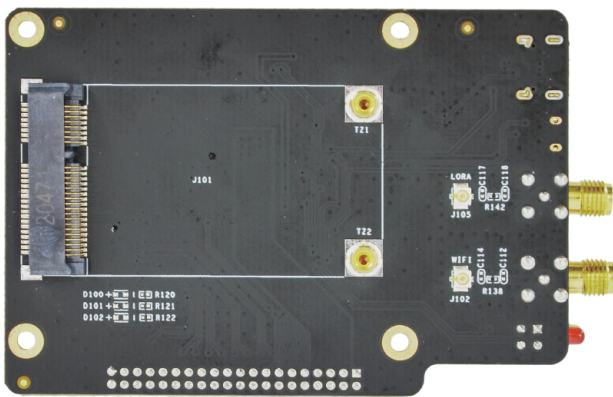

(Front View)

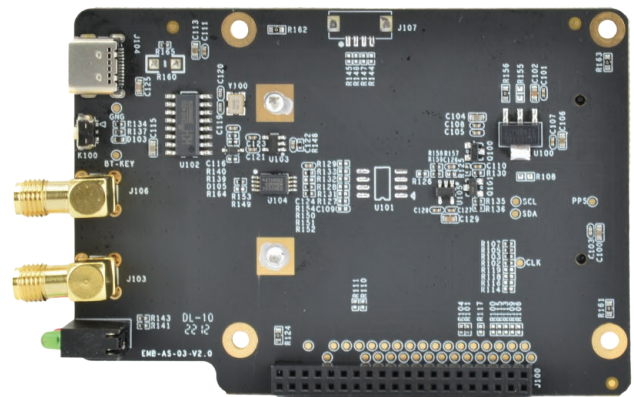

(Back View)

Specification:

I/O Interfaces

USB	1 x USB Type-C Debug (USB to Serial)
Mini PCIe	1 x Mini PCIe (LoRa Module)
Buttons	1 x Bluetooth Pairing Button
LED	1 x Operation Indicator, 1 x Pairing Indicator
External Antenna	1 x LoRa Antenna Connector, 1 x Wifi Antenna Connector
EEPROM	1 x 2Kbit EEPROM
Clipper Chip	1 x Secure Element, eg.ATECC608

Power Supply

Power Input	DC 5V/1A
-------------	----------

Certificates:



I/O Interfaces:

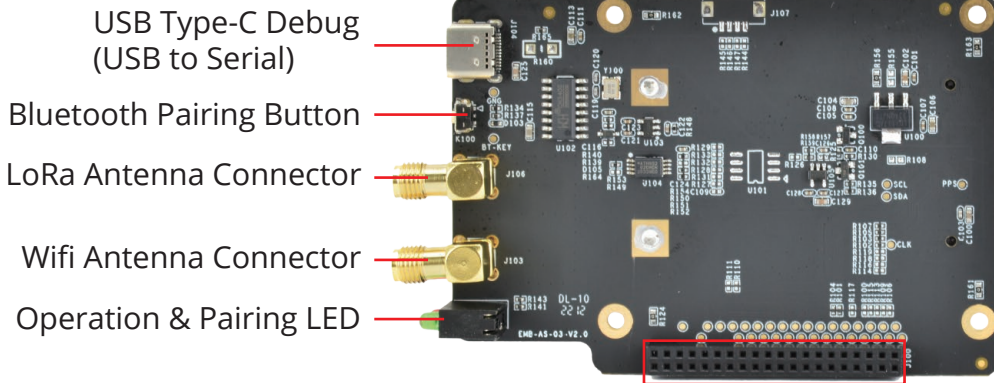

Connection Interface with DEBIX Model A/B and DEBIX Infinity

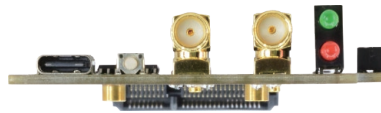
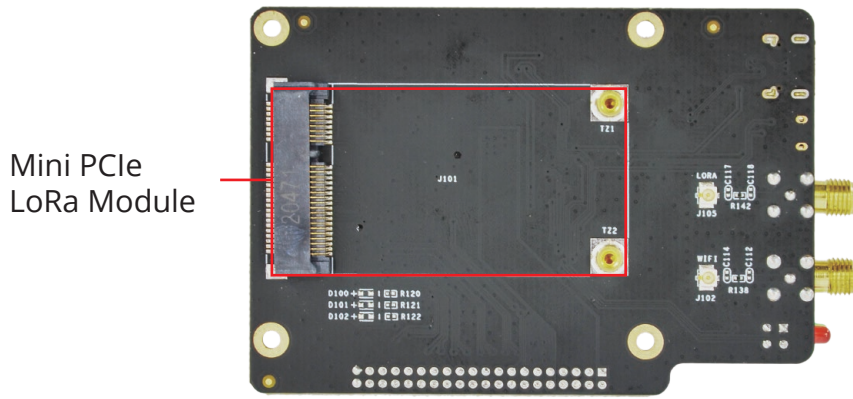

Connection with DEBIX Model A/B:

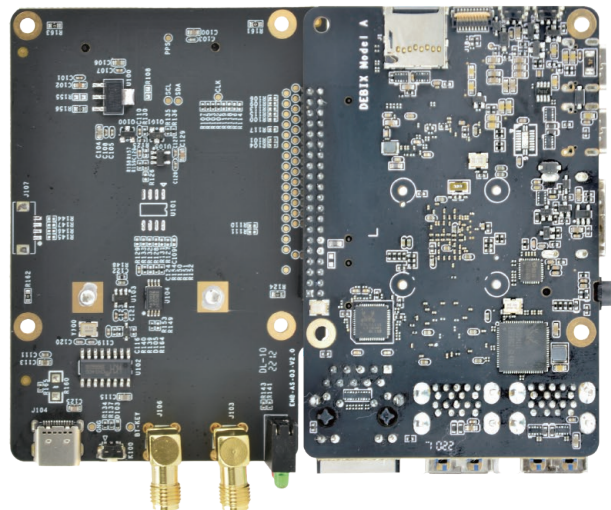
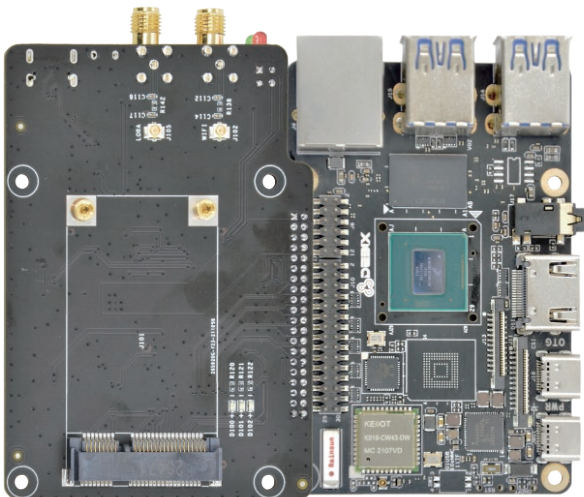

Safety Instruction and Warnings:

General:

- Avoid exposure to water, moisture, and conductive surfaces while operating.
- Handle with care to avoid mechanical or electrical damage to the circuit board and connectors.
- Only handle the board by the edges when powered on to minimize the risk of electrostatic discharge damage.

Environment:

- Operate in a well-ventilated environment, even if using a case.
- Place on a stable, flat, non-conductive surface and avoid contact with conductive items.

Connections:

- Use peripherals that comply with relevant standards for the country of use and ensure proper insulation and operation.

Additional notes:

- This summary is not exhaustive, please refer to the full User Manual for details.
- If you are unsure about any aspect of safety or operation, consult a qualified professional.

Contact Us:

Headquarters: DEBIX Technology Inc., 8345 Gold River Ct., Las Vegas, NV 89113, USA

Factory: 5-6/F., East Zone, Shunheda A2 Building, Liuxiangdong Industrial Park, Xili, Nanshan Dist., Shenzhen, China

Email: info@debix.io

Website: www.debix.io

Community: <https://discord.com/invite/adaHHaDkH2>

